

Pump type:	Dry installed pump
Application:	Waste water, Sewage
Solids passage	3"
Discharge	3"ANSI, 150
Suction	NW100, PN10
Impeller type:	Closed screw impeller
Impeller diameter	220 – 160
Recommended min. flow	57 USGPM
Weight (HX version)	245 lbs

Materials

Pump parts	Cast iron ASTM A-48 CI35
Impeller	S.g. iron ASTM A445 Gr60-46-18
Pump shaft	AISI 431
	Alt: AISI 316
Pump support	S235JR
Bolts	AISI 316
Seal lubrication	Oil
Seal pump side	Silicon carbide – Silicon carbide
Seal motor side	Carbon – Ceramic
Coating	Two component polyurethane

Installation options

Horizontal bare shaft	HX	with motor and support	HM
Vertical bare shaft	VX	with motor and stand	VM
V-belt driven	KM		

Available motors (IP55)

Size	HP	rpm
IEC 112M	2.9	1160
	5.4	1750
IEC 132S	4	1160
	7.4	1750
IEC132M	5.4	1160
	7.4	1160
	10	1750
IEC 160M	10	1160
	14.7	1750

Optional

- Seal flushing

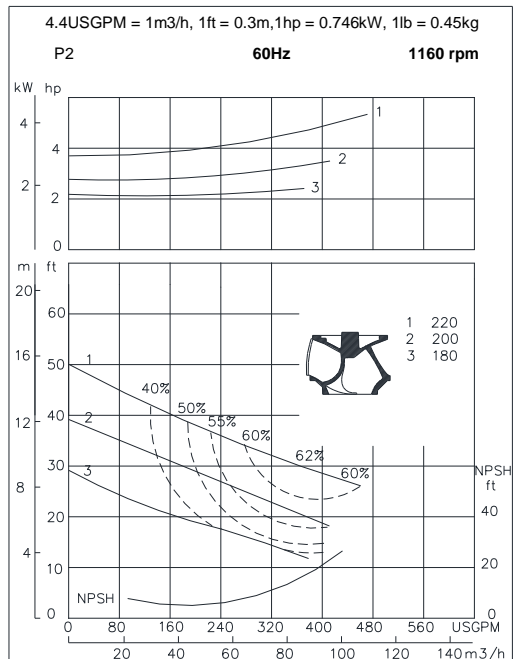
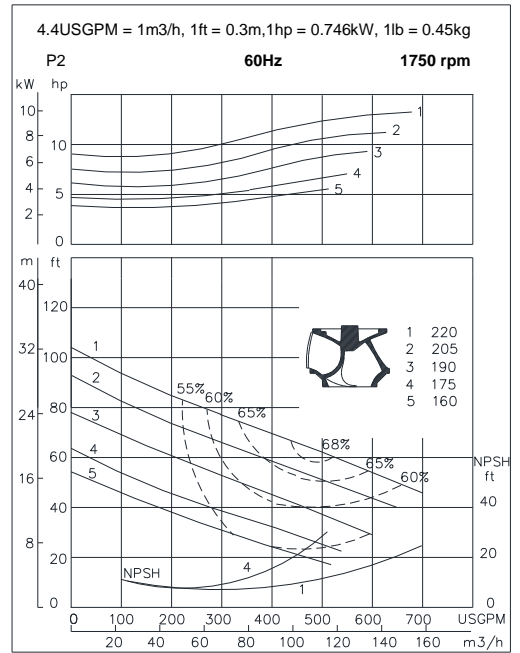
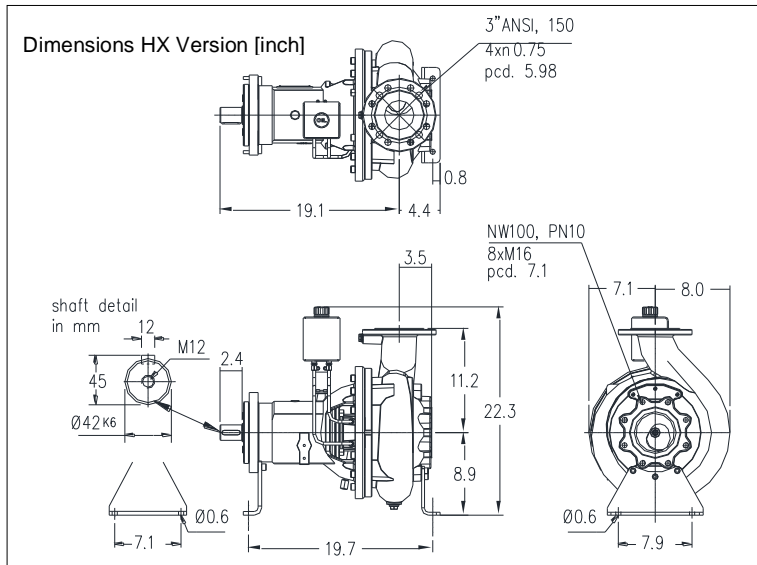

Pump type:	Dry installed pump
Application:	Waste water, Sewage
Solids passage	4"
Discharge	NW100, PN10
Suction	NW125, PN10
Impeller type:	Closed screw impeller
Impeller diameter	250 – 155
Recommended min. flow	92 USGPM
Weight (HX version)	333 lbs

Materials

Pump parts	Cast iron ASTM A-48 CI35
Impeller	S.g. iron ASTM A445 Gr60-46-18
Pump shaft	AISI 431
	Alt: AISI 316
Pump support	S235JR
Bolts	AISI 316
Seal lubrication	Oil
Seal pump side	Silicon carbide – Silicon carbide - FPM
Seal motor side	Carbon – Ceramic - NBR
Coating	Two component polyurethane

Installation options

Horizontal bare shaft	HX	with motor and support	HM
Vertical bare shaft	VX	with motor and stand	VM
V-belt driven	KM		

Available motors (IP55)

Size	HP	rpm
IEC 132S	5	1160
	8.5	1750
IEC132M	6	1160
	8.5	1160
	12	1750
IEC 160M	10	1160
	15	1750
IEC 160L	15	1160
	20	1750
IEC 180M	25	1750

Optional

- Seal flushing

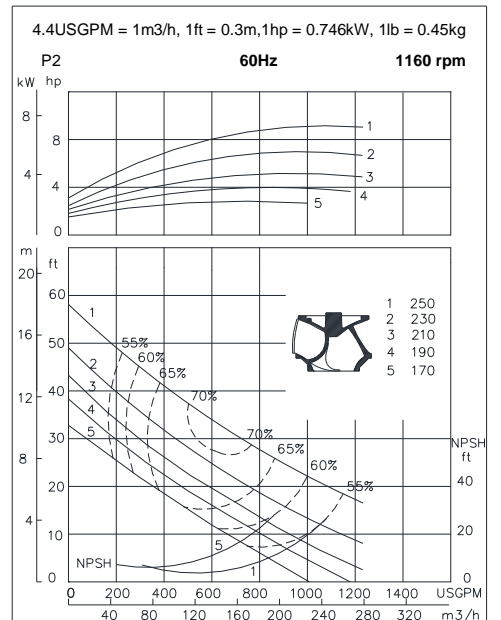
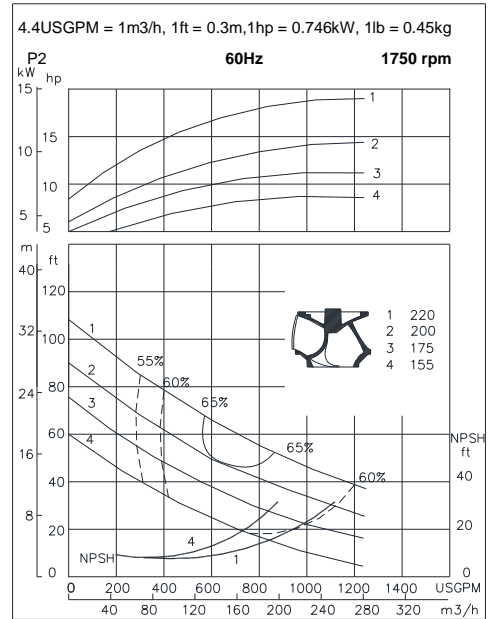
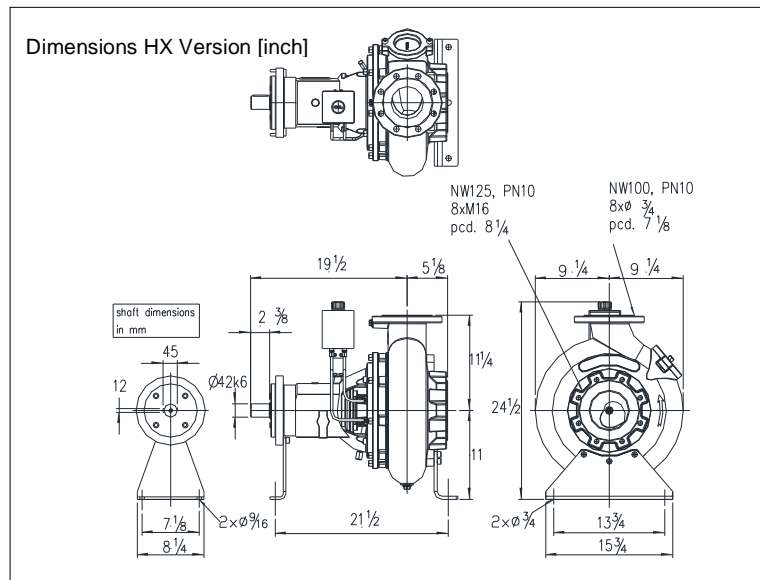

Pump type:	Dry installed pump
Application:	Waste water, Sewage
Solids passage	4"
Discharge	NW150, PN10
Suction	NW150, PN10
Impeller type:	Closed screw impeller
Impeller diameter	255 – 175
Recommended min. flow	207 USGPM
Weight (HX version)	411 lbs

Materials

Pump parts	Cast iron ASTM A-48 CI35
Impeller	S.g. iron ASTM A445 Gr60-46-18
Pump shaft	AISI 431
	Alt: AISI 316
Pump support	S235JR
Bolts	AISI 316
Seal lubrication	Oil
Seal pump side	Silicon carbide – Silicon carbide - FPM
Seal motor side	Carbon – Ceramic - NBR
Coating	Two component polyurethane

Installation options

Horizontal bare shaft	HX	with motor and support	HM
Vertical bare shaft	VX	with motor and stand	VM
V-belt driven	KM		

Available motors (IP55)

Size	HP	rpm
IEC 132S	5	1160
	8.5	1750
IEC132M	6	1160
	8.5	1160
	12	1750
IEC 160M	10	1160
	15	1750
IEC 160L	15	1160
	20	1750
IEC 180M	25	1750

Optional

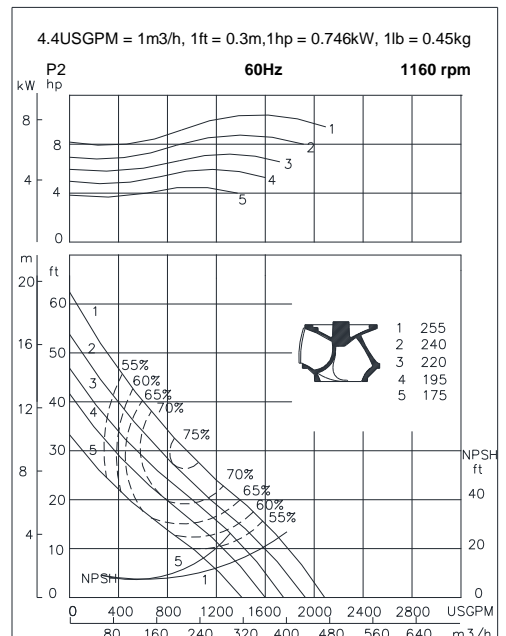
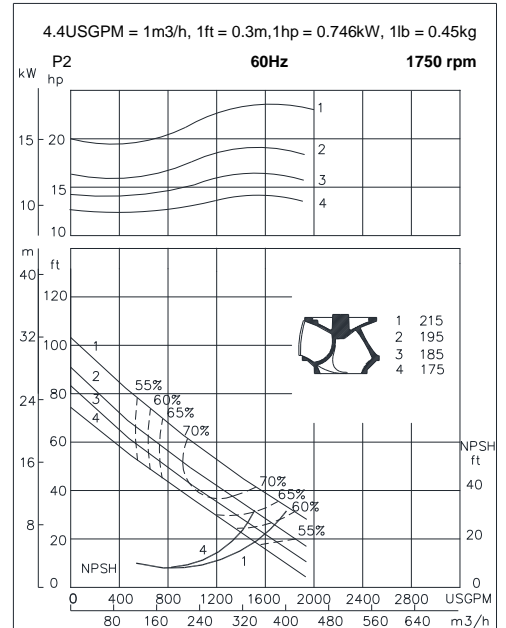
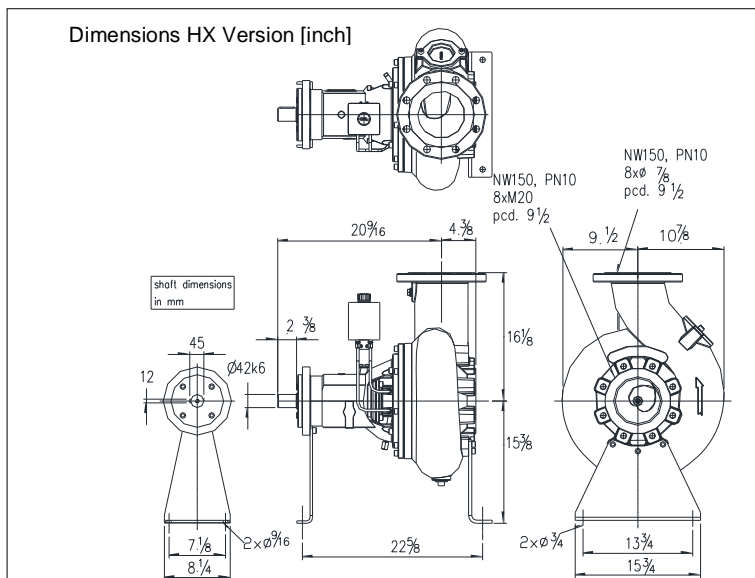

- Seal flushing

Pump type:	Dry installed pump
Application:	Waste water, Sewage
Solids passage	5"
Discharge	6"
Suction	8"
Impeller type:	Closed screw impeller
Impeller code	300 - 210
Recommended min. flow	207 USGPM
Weight (HX version)	620 lbs

Materials

Pump casing/ Seal housing	Cast Iron ASTM A-48 CI35
Impeller	S.g. Iron ASTM A445 Gr60-46-18
Pump shaft	AISI 431
	Alt: AISI 316
Pump support	S235JR
Bolts	AISI 316
Seal lubrication	Oil
Seal pump side	Siliciumcarbide – Siliciumcarbide - FPM
Seal motor side	Carbon – Ceramic - FPM
Coating	Two component Polyurethane

Installation options

Horizontal bare shaft	HX	with motor and support	HM
Vertical bare shaft	VX	with motor and stand	VM
V-belt driven	KM		

Available motors 60 c/s (IP55)

IEC Size	HP	rpm	15.9 USGPM	1 l/s
132M	5	1160	1ft	0.3 m
	7.5	1160	1HP	0.746
			kW	
			1lb	0.45 kg
160M	15	1750		
160L	15	1160		
	20	1750		
180M	25	1750		
180L	20	1160		
	30	1750		

Optional

- Seal flushing

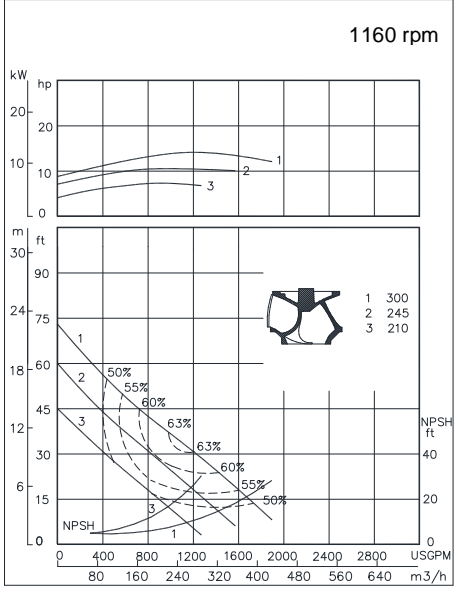
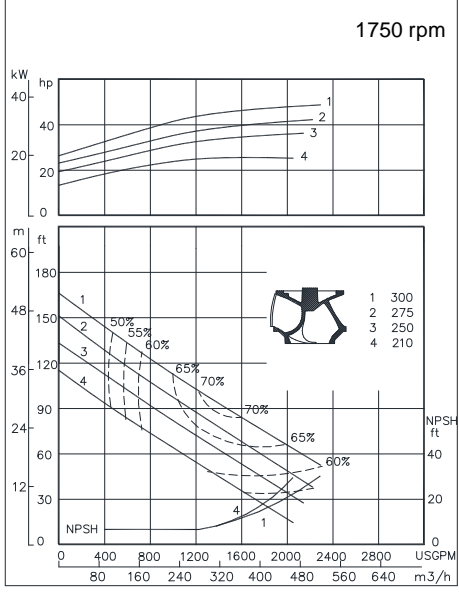
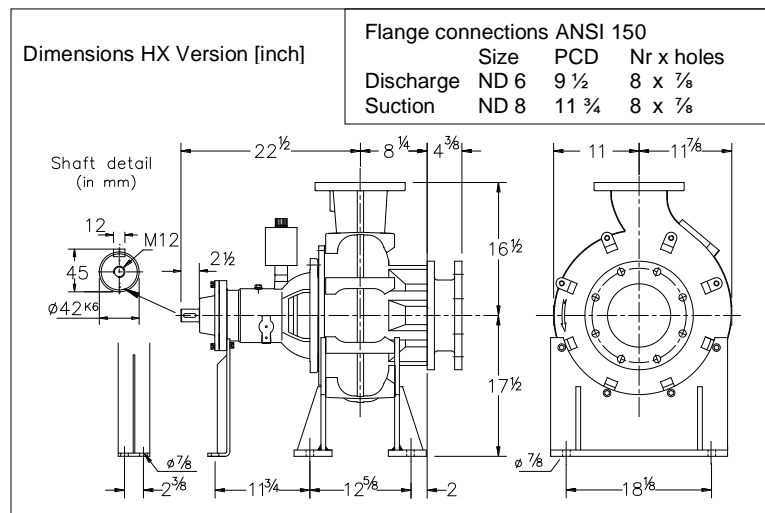

Pump type:	Dry installed pump
Application:	Waste water, Sewage
Solids passage	4¼"x5¼"
Discharge	12"
Suction	10"
Impeller type:	Twin blade closed screw impeller
Impeller code	420 - 300
Recommended min. flow	588 USGPM
Weight (HX version)	1408 lbs

Materials

Pump casing/ Seal housing	Cast Iron ASTM A-48 CI35
Impeller	S.g. Iron ASTM A445 Gr60-46-18
Pump shaft	AISI 431
	Alt: AISI 316
Pump support	S235JR
Bolts	AISI 316
Seal lubrication	Oil
Seal pump side	Siliciumcarbide – siliciumcarbide
Seal motor side	Carbon - ceramic
Coating	Two component polyurethane

Installation options

Horizontal bare shaft	HX	with motor and support	HM
Vertical bare shaft	VX	with motor and stand	VM
V-belt driven	KM		

Available motors 60 c/s (IP55)

IEC Size	HP	rpm	15.9 USGPM	1 l/s
225M	30	900	1ft	0.3 m
250M	40	900	1HP	0.746
	50	1160	kW	
280S	50	900	1lb	0.45 kg
	60	1160		
280M	60	900		
	40	1750		
315S	100	1160		

Optional

- Seal flushing

